



motorola **W388**

Getting Started Guide

congratulations

The Motorola W388 does it all. Take photos and send them to your friends. Or, use the music player to listen to the newest, hottest tracks. All this while you're still connected—take or make calls or exchange messages.

We've crammed all the main features of your phone into this handy guide, and in a matter of minutes we'll show you just how easy your phone is to use. So go on, check it out. Browse the menus and press  to see more. You may be surprised at what you discover.

If you'd like even more information about how to use your new W388, visit www.motorola.com.hk

Note: Before using the phone for the first time, review the *Important Safety and Legal Information* in the back of this guide. Periodically review this information so you remember how to safely use your phone.

contents

your phone	4
menu map	5
let's go	6
basics	7
calls	8
contacts	11
customise	12
shortcuts	14
messages	15
status indicators	17
photo	18
set up music	19
get music	22
play music	27
radio	32
personal organiser	33
USB & memory card	34
web access	37
security	38

your phone



Note: All the illustrations, simulated screen and related images used in this manual are for reference only. There may be slight difference between the handset and keys and content of display used in this manual and those of your handset. Please refer to your handset for actuality.

menu map



Contacts



Recent Calls

- Received calls
- Dialed calls
- Notepad
- Call times
- Call cost*
- Data times*
- Data volume



Messages

- Create
- Inbox
- Draft
- Outbox
- Quick Notes
- Voicemail
- Browser Msgs
- Info services*
- MMS Templates



Extras

- Calculator
- MyMenu
- Alarm clock
- Stop watch
- Chat *
- STK *
- Dialling services
- Calendar



Games & Apps



WebAccess

- Start browser
- Web shortcut
- Go To URL
- Web session
- Stored pages
- History
- General setting



Multimedia

- Camera
- Pictures
- Sounds
- Music
- FM radio



Personalise

- Home Screen
- Main Menu
- Colour Setting
- Greeting
- Wallpaper
- Screensaver
- Quick Dial



Settings

* Network Dependent
This is the standard main menu layout. **Your phone's menu may be different.**

let's go

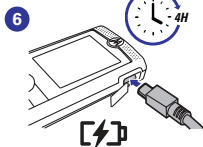
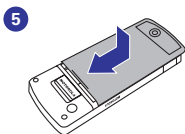
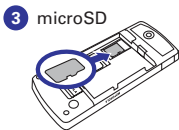
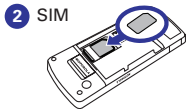
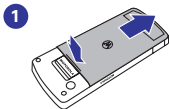

to remove battery

to remove microSD

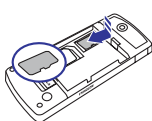

Note: Your battery is intentionally tight fitting.

Gently but firmly push down on the card and slide out.

basics

here's a few essential basics:



turn it on & off

Press and hold  for a few seconds to turn the phone on/off.

menu navigation

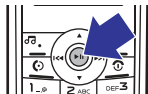



Press the centre key  to open the Main Menu.

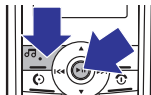

Press the navigation key  up, down, right or left to highlight a menu option.



Press  or **Select** (left soft key) to select the highlighted option.

When the  symbol shows at the bottom of the screen, menu options are available. Press  to display the menu options

calls

it's good to talk.

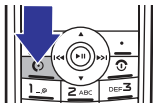

make a call

Enter a number and press .

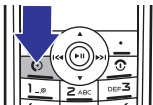

answer a call

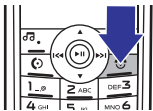

When your phone rings or vibrates, press .



end a call

Press .

redial a number

- 1** From the home screen, press  to see a list of recently dialled calls.
- 2** Scroll to the entry you want to call and press .

calls

go handsfree

To turn the speaker on or off during a call, press **SPKR ON** or **SPKR OFF** (right soft key).

Note: You can also use an optional 2.5 mm wired headset to go handsfree.

in-call menu

During a call you can access the in-call menu by pressing



- **My Tel. Numbers** - see your phone numbers.
- **Mute** - silence your microphone.
- **Hold** - hold the call.
- **New Call** - make a new call.
- **Contacts** - access list of contacts.
- **Received Calls** or **Dialled Calls** - access recent calls.
- **Messages** - access your messages menu.

calls

emergency calls

To call an emergency number, enter the emergency number and press .

Your service provider programs emergency phone numbers, (such as 999), that you can call under any circumstances, even when your phone is locked.

Emergency numbers vary by country. Your phone's pre-programmed emergency number(s) may not work in all locations, and sometimes an emergency call cannot be placed due to network, environmental, or interference issues.



contacts

made a new friend?

save a contact



- 1 Enter the number on the home screen and press **Store**.
- 2 Enter the contact details and press **Done** when you're finished.

call a contact

- 1 Press  >  **Contacts**.
- 2 Scroll through the list to highlight the contact.
- 3 Press .

customise your contacts

Why not set a **ring tone** or **photo** for your new friend?

Find it:  >  **Contacts** >  > **Edit** > **Sound** or **Picture**

Note: You can only use custom ring tones and pictures for contacts that are stored on your phone memory, not on the SIM. Photos must be ones taken with your phone.

customise

go ahead, add your personal touch...

create shortcuts

Choose the features you want to access with a single key press from the home screen—really useful stuff:

Find it:  >  Personalise > Home Screen > Home Keys

set your wallpaper & screensaver

Change the wallpaper and screensaver images to ones that make you smile.

Find it:  >  Personalise > Wallpaper or Screensaver

Note: Your screensaver setting is overridden by the **Auto** key lock.

set ringtone & volume

There are times when you want to hear your ringtone, and times when you don't.

Find it:  >  Settings > Ring Style

customise



Choose from the pre-programmed styles, including **Vibrate** and **Silent**.

customise your menu

Create a custom menu of your favourite features and tools using the MyMenu feature.

Scroll to a desired menu item and press and hold  until the **MyMenu** confirmation appears and press **OK**.

Scroll to **Key** and select **Change**. Enter a key number to assign to your menu item.

To use **MyMenu**, open the main menu, then simply press the number key you assigned to the feature. For example, if you assigned **Messages** to  then press  > .

shortcuts



some quick access shortcuts from the home screen.

options	
music player	To quickly access the music player, simply press  .
take a photo	Press  >  Multimedia > Camera to see the viewfinder. Press Capture to take the photo.
quick text	Use quick text to access the Message screen with a single key press. To set quick text on your home screen, press  >  Personalise > Home Screen > Home Keys > key > Change > Quick Txt.
change ring style to Vibrate	Press and hold  .
dialled calls	Press  .
voicemail	Press and hold  . If your voicemail number is pre-set, you will connect.

messages

sometimes it's better 2 say it in a message.

create & send a message

- 1 Press  >  **Messages** > **Create**.
- 2 Select a message type and enter the message text (see page 16).
- 3 To insert a picture, sound, or other object, press **Insert**.
- 4 When you finish the message, press **OK**. Choose one or more people to send to and press **Send**.

receive a message

Press **Read** to read the message immediately, or save it in your message inbox for viewing later.

Find it:  >  **Messages** > **Inbox**

voicemail

When you **receive** a voicemail message, your phone shows an indicator and **New Voicemail**. Press **Call** to call your voicemail and follow the prompts.



messages

enter text

When you are in a text entry screen, press **#** to switch text entry modes (Primary, Secondary, Numeric and Symbol).

To assign Primary and Secondary entry modes, press **⬅** > **Entry setup** > **Primary Setup** or **Secondary Setup** from the text entry screen:

- tap English - Standard method for entering text on your phone. Regular Tap method cycles through the letters and numbers of the key you press.
- iTAP™ English - Combines your single key presses and predicts each word as you enter it. If the word is not correct, press **⬅** right or left to scroll through the possible combinations.

When entering text, press ***** to enter a space and move on the next word. Press **1** to enter punctuation. Press **0** to switch capitalisation modes if you need to (although in most cases this is done for you).

status indicators

to keep you updated at all times.

Status indicators can appear across the **top of the home screen** (your phone's home screen may be different than the one shown):

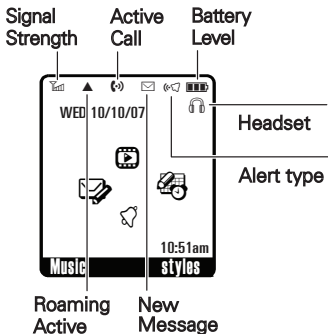

photo

see it, capture it, send it!

- ❶ Press  >  **Multimedia** > **Camera** to see the viewfinder.

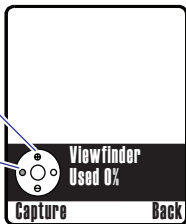

Press  up/down to zoom in/out.

Press  right/left to adjust level of brightness.



- ❷ Press **Capture** to take the photo.
- ❸ Press **Store** > **Send in Message** to send the photo in a message. 

Note: Before taking your photo, you can press  to open the camera menu. From here you can access features such as **Auto-Timed Capture**, **Picture Setup** and **View Free Space**.

To find your photos, press  >  **Multimedia** > **Pictures** or go to your memory card by pressing  > **Switch storage devices** > **Memory card**.

set up music

when music is what you need...

what music transfer tools do I need?

To put music on your PC and then load it on your phone, you need:

- Microsoft™ Windows™ XP or Windows Vista™ PC.
- USB data cable (may be sold separately).
- Microsoft Windows Media Player version 10 or later, available from www.microsoft.com.

do I need a memory card?

Simple answer, yes.

Your phone supports removable microSD memory cards, from various manufacturers, with up to 2 GB capacity. We recommend that you use Motorola approved memory cards.

set up music

format memory card

Don't forget to format a memory card before using it for the first time (see page 34).

what music file formats can I play?

Your phone can play many types of music files: MP3, AMR, MIDI and iMelody.

Note: Your phone may not play MP3 files that have a bit rate of 320 kbps or higher. If you try to download or play one of these files, your phone may display an error message or ask you to delete the file.

do I need a USB cable?

A USB data cable (may be sold separately) is required, unless you have a removable memory card and a memory card reader, in which case see page 25.

set up music

what headphones can I use?

Your phone has a 2.5 mm headset jack for wired stereo listening. Mini USB headsets are not supported.

Note: We recommend that you use Motorola approved headphones for the best audio quality.

get music

get your favourite tunes...

rip songs from a CD

Well, not literally. If you're new to music this means transferring songs from an audio CD to your PC. To do this, you need Microsoft™ Windows™ Media Player version 10 or later. You can download Windows Media Player from www.microsoft.com.

- 1 On your PC**, launch Windows Media Player.
- 2** Insert an audio CD into your PC's CD ROM drive.
Note: Make sure you change the format to MP3, AMR, MIDI or iMelody in the Rip Settings. (MP3 is the recommended format for best performance.)
- 3** In the Windows Media Player window, click on the "Rip" tab.
- 4** Highlight the songs you want to import and click "Rip Music."

The songs are imported to the Windows Media Player Library. Next, transfer the songs from your PC to your memory card.

get music

load music

Transfer files from a PC to a removable memory card.

Note: Your phone does not support DRM protected music files. The unauthorized copying of copyrighted materials is contrary to the provisions of the Copyright Laws of the United States and other countries. This device is intended solely for copying non-copyrighted materials, materials in which you own the copyright, or materials which you are authorized or legally permitted to copy. If you are uncertain about your right to copy any material, please contact your legal advisor.

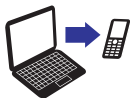

PC to memory card

Got a USB data cable to hand? Good, let's start loading your music onto your phone:

- 1** With a memory card inserted and your phone in the home screen, insert the USB cable in your phone and your Windows PC.
- 2** On your phone, press **Yes** to connect your phone as a storage device.

get music

- 3 Now you've connected, use **Windows Media Player** or **USB drag and drop** to copy your music.

Windows Media Player

- 1 On your **Windows PC**, open Windows Media Player 11.
- 2 If you are not prompted to rename your phone, on the **Sync** tab, select **More Options**. Under Devices, select **REMOVABLE DISK** (memory card) and rename to "W388 Mobile".

Note: You can select **MOT-W388** (internal memory) but your memory card has a lot more space for your music.

USB drag and drop

- 1 Use the **My Computer** window to find **REMOVABLE DISK** (memory card).

Note: When your phone is plugged into a PC and is being used as a mass storage device, it cannot be used for anything else. To restore the phone to normal use, disconnect it from the PC.

get music

- 2 Drag and drop the music that you want to copy onto your memory card.

Note: You can select **MOT-W388** (internal memory) but your memory card has a lot more space for your music.

- 3 When you're done, use the **Safely Remove Hardware** feature to finish.

using a memory card reader

To transfer files using a memory card reader, insert your memory card into the card reader (you may first need to insert the card into an adapter that fits into the card reader). Insert the card reader into an available USB port on your PC.

- 1 On your Windows PC, open "My Computer" and click on **REMOVABLE DISK** to access your phone's memory card.
- 2 In the memory card window, create one or more folders for the files you will copy onto the memory card.

A file name (including the path) must be less than 255 characters. For example, if you copy songs into

get music

a folder you create that is named “MyMotoSongs,” the name of any song PLUS the name of the folder “MyMotoSongs” must be less than 255 characters.









- 3** Drag and drop desired files into the memory card window.
- 4** When finished, disconnect by clicking on the “Safely Remove Hardware” icon in the system tray on your PC screen, selecting “USB Mass Storage Device,” and selecting “Stop.”

play music

listen to your favourite tunes...

A short press of the music key () opens your phone's **Music** menu (see page 4 for music key location). Select **Music** to open the music player.

Use these keys to control the music player:

controls	
scroll through song list	Before music playback, press  up or down.
play	Press  .
pause/resume	Press  .
fast forward	Press & hold  right.
next song	Press & release  right.
rewind	Press & hold  left.
previous song	Press & release  left.
turn off	Press  .

play music

repeat, shuffle, & other options

Press **Options** while using the music player to choose from these options:

menu items	
Delete	Delete the current track.
Send in message	Send the current track in an MMS.
Apply to	Add your favourite song to a playlist or set as your ringtone.
Music Store	Go to an on-line music store.
Details	See details of the current track.
Setup	Set Auto repeat and Shuffle options
View Free Space	View space remaining on your phone.

play music

wake up music player

While the music player is active, your phone may conserve battery power by turning off the display and keypad backlights.

To turn display and back lights back on, press any key.

turn off music player

Easy, just press .

music player tips

- If you receive a call while playing music, the music pauses. You can **Ignore** the call and send the caller to voicemail or **Answer** the call. Playing resumes when you end the call.
- To hide your music player while a song is playing, press **Options > Hide**. If the music player is hidden, you can use other phone features. But, using applications like **Games & Apps** or **FM radio** turns the music player off.

play music

playlists

create a playlist

Find it:  > **Music** > **Playlists** > **[New Playlist]**

- 1** Press **Change**, enter a name for the playlist and press **OK**.
- 2** Scroll to **Audio Files** and press **Change**. Scroll to the song you want to add and press **Check**.

When you select a song, a ✓ appears beside the song. (To unselect a song, scroll to the song and press **Uncheck**.)
- 3** Keep adding songs until you've created your playlist, and then press **Done**.

play a playlist

To play a playlist, press  > **Music** > **Playlists**, scroll to a playlist and press **Options** > **Play**.

delete a playlist

Scroll to a playlist and press **Options** > **Delete Playlist** to delete the playlist.

play music

reorder a playlist

- 1 Scroll to a playlist and press **Options > Reorder**.
- 2 Scroll to the song you want to move and press **Grab**.
- 3 Scroll to the position in the playlist where you want to move the song, and press **Insert**.
- 4 When you are finished, press **Done**.



radio

listen to your favourite news or music programme.

❶ Plug a 2.5 mm headset into your phone.

Note: The FM radio works only when the headset is plugged in.

❷ Press  >  **Multimedia** > **FM Radio**.

To tune in a station, press  or .

To scan available stations, press and hold  left or right. Repeat to go to more stations.

To adjust volume, press  up or down.

To turn off the radio, press **Options** > **FM Radio Off**.

store favourite stations

When listening to a station, press and hold a number key **1** through **9** to store the station as a preset for that number key. To select a preset station, press the number key for the station you want.

personal organiser

stay on top of things with these handy features.

add & view calendar event

Find it:  >  Extras > Calendar

Scroll to the desired day and press **Select**, then scroll to **[New]** and press **Select** to add, or scroll to the event and press **View** to view.

Note: When an event reminder occurs, press **View** to view it. Press **Exit** to dismiss it.

set alarm

Find it:  >  Extras > Alarm Clock

Tip: You can set the FM radio as your alarm device by selecting **Alert** > **Radio** from the **Alert Method** menu.

calculator

Find it:  >  Extras > Calculator

Tip: To convert currency, press  and select **Convert Currency**.

USB & memory card

connect your phone and PC, then drag & drop.



format

You need to format a memory card, **using the phone**, before using it for the first time. This creates the necessary folders and ensures your phone can read the contents of the card.

Caution: Formatting the memory card erases all content on the card.

Find it:  >  **Settings** > **Initial Setup**

- 1** Scroll to **Format Additional Storage Device**
- 2** When prompted, press **Yes** to continue or **No** to cancel formatting.

Tip: To access material stored on your microSD memory card, with your phone in the home screen, press  >  **Multimedia** > **Sounds** or **Pictures** and then press  > **Switch Storage Device**. If there are no files stored on your memory card, your phone will automatically switch to its internal memory.

USB & memory card

drag & drop

Note: Your phone supports Microsoft Windows XP™ and Windows Vista™. Other operating systems may not be compatible with your phone.

- 1 With your phone in the home screen, insert the USB cable in your phone and your Windows PC. Select **Yes** to connect the phone as a storage device.
- 2 Use the **My Computer** window to find **REMOVABLE DISK** (memory card) or **MOT-W388** (phone memory).

Note: When your phone is plugged into a PC and is being used as a mass storage device, it cannot be used for anything else. To restore the phone to normal use, disconnect it from the PC.

- 3 Drag and drop your music, photos and other stuff that you want to copy. Copy pictures to the **picture** folder. Music files can be copied anywhere onto the memory card.

USB & memory card



Note: You can copy music files to **MOT-W388** (phone internal memory) but your memory card has a lot more space for your music.

A music or picture file name (including the path) must be less than 255 characters.

- 4 Use the **Safely Remove Hardware** feature to finish.

web access

you don't need a PC, surf the web with your phone.

Find it:  >  WebAccess

feature

open the web browser

 >  WebAccess > Start Browser

go to a Web page

 >  WebAccess > Go To URL

download objects from a Web page

 >  WebAccess > Start Browser > *page* > *link*

create and access Web page shortcuts

 >  WebAccess > Web Shortcut

security

help to keep your phone secure.

codes & passwords

Your phone's four-digit **unlock code** is originally set to **1234** or to the last four digits of your phone number. The six-digit **security code** is originally set to **000000**.

To change a code or password:

Find it:  >  Settings > Security > New Passwords

lock & unlock phone

You can lock your phone to keep others from using it.

Find it:  >  Settings > Security > Phone Lock > Lock Now
or Automatic Lock

Enter the four-digit unlock code and press **OK**. Your phone first displays **Phone Locked**, and then shows **Enter Unlock Code** : until the next time you unlock your phone.

To unlock your phone, enter your four-digit code and press **OK**.

Legal and Safety Information

www.motorola.com.hk

Certain mobile phone features are dependent on the capabilities and settings of your service provider's network. Additionally, certain features may not be activated by your service provider, and/or the provider's network settings may limit the feature's functionality. Always contact your service provider about feature availability and functionality. All features, functionality, and other product specifications, as well as the information contained in this user's guide are based upon the latest available information and are believed to be accurate at the time of printing. Motorola reserves the right to change or modify any information or specifications without notice or obligation.

Software Copyright Notice

The Motorola products described in this manual may include copyrighted Motorola and third-party software stored in semiconductor memories or other media. Laws in the United States and other countries preserve for Motorola and third-party software providers certain exclusive rights for copyrighted software, such as the exclusive rights to distribute or reproduce the copyrighted software. Accordingly, any copyrighted software contained in the Motorola products may not be modified, reverse-engineered, distributed, or reproduced in any manner to the extent allowed by law. Furthermore, the purchase of the Motorola products shall not be deemed to grant either directly or by implication, estoppel, or otherwise, any license under the copyrights, patents, or patent applications of Motorola or any third-party software provider, except for the normal, non-exclusive, royalty-free license to use that arises by operation of law in the sale of a product.

battery use & safety

IMPORTANT: HANDLE AND STORE BATTERIES PROPERLY TO AVOID INJURY OR DAMAGE. Most battery issues arise from improper handling of batteries, and particularly from the continued use of damaged batteries.

DON'Ts

- **Don't disassemble, crush, puncture, shred, or otherwise attempt to change the form of your battery.**
- **Don't let the phone or battery come in contact with water.** Water can get into the phone's circuits, leading to corrosion. If the phone and/or battery get wet, have them checked by your carrier or contact Motorola, even if they appear to be working properly.
- **Don't allow the battery to touch metal objects.** If metal objects, such as jewelry, stay in prolonged contact with the battery contact points, the battery could become very hot.
- **Don't place your battery near a heat source.** Excessive heat can damage the phone or the battery. High temperatures can cause the battery to swell, leak, or malfunction. Therefore:
- Do **not** dry a wet or damp battery with an appliance or heat source, such as a hair dryer or microwave oven.
- Avoid leaving your phone in your car in high temperatures.

DOs

- **Do avoid dropping the battery or phone.** Dropping these items, especially on a hard surface, can potentially cause damage.
- **Do contact your service provider or Motorola if your phone or battery has been damaged from dropping or high temperatures.**

IMPORTANT: USE MOTOROLA ORIGINAL PRODUCTS FOR QUALITY ASSURANCE AND SAFEGUARDS. To aid consumers in identifying

authentic Motorola batteries from non-original or counterfeit batteries (that may not have adequate safety protection), Motorola provides holograms on its batteries. Consumers should confirm that any battery they purchase has a “Motorola Original” hologram.

Motorola recommends you always use Motorola-branded batteries and chargers. Motorola mobile devices are designed to work with Motorola batteries. If you see a message on your display such as **Invalid Battery** or **Unable to Charge**, take the following steps:



- Remove the battery and inspect it to confirm that it has a “Motorola Original” hologram;
- If there is no hologram, the battery is not a Motorola battery;
- If there is a hologram, replace the battery and retry charging it;
- If the message remains, contact a Motorola Authorized Service Center.

Important: Motorola’s warranty does not cover damage to the phone caused by non-Motorola batteries and/or chargers.

Warning: Use of a non-Motorola battery or charger may present a risk of fire, explosion, leakage, or other hazard.

PROPER AND SAFE BATTERY DISPOSAL AND RECYCLING

Proper battery disposal is not only important for safety, it benefits the environment. Consumers may recycle their used batteries in many retail or service provider locations. Additional information on proper disposal and recycling may be found on the Web:

- www.motorola.com/recycling
- www.rbc.org/call2recycle/ (in English only)

Disposal: Promptly dispose of used batteries in accordance with local regulations. Contact your local recycling center or national recycling organizations for more information on how to dispose of batteries.



Warning: Never dispose of batteries in a fire because they may explode.

Specific Absorption Rate Data

This model meets international guidelines for exposure to radio waves.

Your mobile device is a radio transmitter and receiver. It is designed not to exceed the limits for exposure to radio waves recommended by international guidelines. These guidelines were developed by the independent scientific organization ICNIRP and include safety margins designed to assure the protection of all persons, regardless of age and health.

The guidelines use a unit of measurement known as the Specific Absorption Rate, or SAR. The ICNIRP SAR limit for mobile devices used by the general public is 2 W/kg and the highest SAR value for this device when tested at the ear is 1.27 W/kg.¹ As mobile devices offer a range of functions, they can be used in other positions, such as on the body as described in this user's guide.² In this case, the highest tested SAR value is 0.68 W/kg.¹

As SAR is measured utilizing the device's highest transmitting power, the actual SAR of this device while operating is typically below that indicated above. This is due to automatic changes to the power level of the device to ensure it only uses the minimum level required to reach the network.

While there may be differences between the SAR levels of various phones and at various positions, they all meet the governmental requirements for safe exposure. Please note that improvements to this product model could cause differences in the SAR value for later products; in all cases, products are designed to be within the guidelines.

The World Health Organization has stated that present scientific information does not indicate the need for any special precautions for the use of mobile devices. They note that if you want to reduce your exposure then you can do so by limiting the length of calls or using a "handsfree" device to keep the mobile phone away from the head and body.

Additional Information can be found on the websites of the World Health Organization (<http://www.who.int/emf>) or Motorola, Inc. (<http://www.motorola.com/rfhealth>).

1. The tests are carried out in accordance with international guidelines for testing. The limit incorporates a substantial margin for safety to give additional protection for the public and to account for any variations in measurements. Additional related information includes the Motorola testing protocol, assessment procedure, and measurement uncertainty range for this product.
2. Please see the *Safety and General Information* section about body worn operation.

European Union Directives Conformance Statement



Hereby, Motorola declares that this product is in compliance with:

- The essential requirements and other relevant provisions of Directive 1999/5/EC
- All other relevant EU Directives

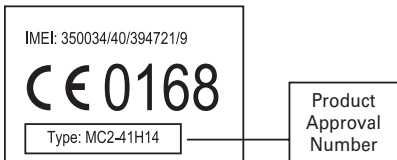

The above gives an example of a typical Product Approval Number.

You can view your product's Declaration of Conformity (DoC) to Directive 1999/5/EC (to R&TTE Directive) at www.motorola.com/rtte. To find your DoC, enter the Product Approval Number from your product's label in the "Search" bar on the Web site.

Safety and General Information

This section contains important information on the safe and efficient operation of your mobile device. Read this information before using your mobile device.

Exposure to Radio Frequency (RF) Energy

Your mobile device contains a transmitter and receiver. When it is ON, it receives and transmits RF energy. When you communicate with your mobile device, the system handling your call controls the power level at which your mobile device transmits.

Your Motorola mobile device is designed to comply with local regulatory requirements in your country concerning exposure of human beings to RF energy.

Operational Precautions

For optimal mobile device performance, and to be sure that human exposure to RF energy does not exceed the guidelines set forth in the relevant standards, always follow these instructions and precautions.

Product Operation

When placing or receiving a phone call, hold your mobile device just like you would a landline phone.

If you wear the mobile device on your body, always place the mobile device in a Motorola-supplied or approved clip, holder, holster, case, or body harness. If you do not use a body-worn accessory supplied or approved by Motorola—or if you hang your mobile device from a lanyard around your neck—keep the mobile device and its antenna at least 2.5 centimeters (1 inch) from your body when transmitting.

Using accessories not supplied or approved by Motorola may cause your mobile device to exceed RF energy exposure guidelines. For a list of Motorola-supplied or approved accessories, visit our Web site at:

www.motorola.com.hk

RF Energy Interference/Compatibility

Nearly every electronic device is subject to RF energy interference from external sources if inadequately shielded, designed, or otherwise configured for RF energy compatibility. In some circumstances your mobile device may cause interference with other devices.

Follow Instructions to Avoid Interference Problems

Turn off your mobile device in any location where posted notices instruct you to do so.

In an aircraft, turn off your mobile device whenever instructed to do so by airline staff. If your mobile device offers an airplane mode or similar feature, consult airline staff about using it in flight.

Implantable Medical Devices

If you have an implantable medical device, such as a pacemaker or defibrillator, consult your physician before using this mobile device.

Persons with implantable medical devices should observe the following precautions:

- ALWAYS keep the mobile device more than 20 centimeters (8 inches) from the implantable medical device when the mobile device is turned ON.
- DO NOT carry the mobile device in the breast pocket.
- Use the ear opposite the implantable medical device to minimize the potential for interference.
- Turn OFF the mobile device immediately if you have any reason to suspect that interference is taking place.

Read and follow the directions from the manufacturer of your implantable medical device. If you have any questions about using your mobile device with your implantable medical device, consult your healthcare provider.

Driving Precautions

The use of wireless phones while driving may cause distraction. Discontinue a call if you can't concentrate on driving.

Additionally, the use of wireless devices and their accessories may be prohibited or restricted in certain areas. Always obey the laws and regulations on the use of these products.

Responsible driving practices can be found in the “Smart Practices While Driving” section in this guide (or separate guide).

Operational Warnings

Obey all posted signs when using mobile devices in public areas.



Potentially Explosive Atmospheres



Areas with potentially explosive atmospheres are often, but not always, posted and can include fueling areas, such as below decks on boats, fuel or chemical transfer or storage facilities, or areas where the air contains chemicals or particles, such as grain dust, or metal powders.

When you are in such an area, turn off your mobile device, and do not remove, install, or charge batteries. In such areas, sparks can occur and cause an explosion or fire.

Symbol Key

Your battery, charger, or mobile device may contain symbols, defined as follows:

Symbol	Definition
	Important safety information follows.
	Do not dispose of your battery or mobile device in a fire.
	Your battery or mobile device may require recycling in accordance with local laws. Contact your local regulatory authorities for more information.

Symbol	Definition
	Do not throw your battery or mobile device in the trash.
	Do not let your battery, charger, or mobile device get wet.
	Listening at full volume to music or voice through a headset may damage your hearing.

Batteries & Chargers

Caution: Improper treatment or use of batteries may present a danger of fire, explosion, leakage, or other hazard. For more information, see the “battery use & safety” section in this guide.

Keep Your Mobile Device and Its Accessories Away From Small Children

These products are not toys and may be hazardous to children. For example:

- A choking hazard may exist for small, detachable parts.
- Improper use could result in loud sounds, possibly causing hearing injury.
- Improperly handled batteries could overheat and cause a burn.

Glass Parts

Some parts of your mobile device may be made of glass. This glass could break if the product is dropped on a hard surface or receives a substantial impact. If glass breaks, do not touch or attempt to remove. Stop using your mobile device until the glass is replaced by a qualified service center.

Seizures/Blackouts

Some people may be susceptible to epileptic seizures or blackouts when exposed to flashing lights, such as when playing video games. These may occur even if a person has never had a previous seizure or blackout.

If you have experienced seizures or blackouts, or if you have a family history of such occurrences, please consult with your physician before playing video games or enabling a flashing-lights feature (if available) on your mobile device.

Discontinue use and consult a physician if any of the following symptoms occur: convulsion, eye or muscle twitching, loss of awareness, involuntary movements, or disorientation. It is always a good idea to hold the screen away from your eyes, leave the lights on in the room, take a 15-minute break every hour, and stop use if you are tired.

Caution About High Volume Usage



Warning: Exposure to loud noise from any source for extended periods of time may affect your hearing. The louder the volume sound level, the less time is required before your hearing could be affected. To protect your hearing:

- Limit the amount of time you use headsets or headphones at high volume.
- Avoid turning up the volume to block out noisy surroundings.
- Turn the volume down if you can't hear people speaking near you.

If you experience hearing discomfort, including the sensation of pressure or fullness in your ears, ringing in your ears, or muffled speech, you should stop listening to the device through your headset or headphones and have your hearing checked.

For more information about hearing, see our Web site at www.motorola.com/hearingsafety (in English only).

Repetitive Motion

When you repetitively perform actions such as pressing keys or entering finger-written characters, you may experience occasional discomfort in your hands, arms, shoulders, neck, or other parts of your body. If you continue to have discomfort during or after such use, stop use and see a physician.

[Mar0108]

Use and Care

To care for your Motorola phone, please keep it away from:



liquids of any kind

Don't expose your phone to water, rain, extreme humidity, sweat, or other moisture. If it does get wet, don't try to accelerate drying with the use of an oven or dryer, as this may damage the phone.



extreme heat or cold

Avoid temperatures below 0°C/32°F or above 45°C/113°F.



microwaves

Don't try to dry your phone in a microwave oven.



dust and dirt

Don't expose your phone to dust, dirt, sand, food, or other inappropriate materials.



cleaning solutions

To clean your phone, use only a dry soft cloth. Don't use alcohol or other cleaning solutions.



the ground

Don't drop your phone.

FCC Notice to Users

The following statement applies to all products that have received FCC approval. Applicable products bear the FCC logo, and/or an FCC ID in the format FCC-ID:xxxxxx on the product label.

Motorola has not approved any changes or modifications to this device by the user. Any changes or modifications could void the user's authority to operate the equipment. See 47 CFR Sec. 15.21.

This device complies with part 15 of the FCC Rules. Operation is subject to the following two conditions: (1) This device may not cause harmful interference, and (2) this device must accept any interference received, including interference that may cause undesired operation. See 47 CFR Sec. 15.19(3).

This equipment has been tested and found to comply with the limits for a Class B digital device, pursuant to part 15 of the FCC Rules. These limits are designed to provide reasonable protection against harmful interference in a residential installation. This equipment generates, uses and can radiate radio frequency energy and, if not installed and used in accordance with the instructions, may cause harmful interference to radio communications. However, there is no guarantee that interference will not occur in a particular installation. If this equipment does cause harmful interference to radio or television reception, which can be determined by turning the equipment off and on, the user is encouraged to try to correct the interference by one or more of the following measures:

- Reorient or relocate the receiving antenna.
- Increase the separation between the equipment and the receiver.
- Connect the equipment to an outlet on a circuit different from that to which the receiver is connected.

- Consult the dealer or an experienced radio/TV technician for help.

Information from the World Health Organization

Present scientific information does not indicate the need for any special precautions for the use of mobile phones. If you are concerned, you may want to limit your own or your children's RF exposure by limiting the length of calls or by using handsfree devices to keep mobile phones away from your head and body.

Source: WHO Fact Sheet 193

Further information: <http://www.who.int/peh-emf>

Caring for the Environment by Recycling



This symbol on a Motorola product means the product should not be disposed of with household waste.

Disposal of your Mobile Device and Accessories

Please do not dispose of mobile devices or electrical accessories (such as chargers, headsets, or batteries) with your household waste. These items should be disposed of in accordance with the national collection and recycling schemes operated by your local or regional authority. Alternatively, you may return unwanted mobile devices and electrical accessories to any Motorola Approved Service Center in your region. Details of Motorola approved national recycling schemes, and further information on Motorola recycling activities can be found at: www.motorola.com/recycling

Disposal of your Mobile Device Packaging and User's Guide

Product packaging and user's guides should only be disposed of in accordance with national collection and recycling requirements. Please contact your regional authorities for more details.

Privacy and Data Security

Motorola understands that privacy and data security are important to everyone. Because some features of your mobile device may affect your privacy or data security, please follow these recommendations to enhance protection of your information:

- **Monitor access**—Keep your mobile device with you and do not leave it where others may have unmonitored access. Lock your device's keypad where this feature is available.
- **Keep software up to date**—If Motorola or a software/application vendor releases a patch or software fix for your mobile device that updates the device's security, install it as soon as possible.
- **Erase before recycling**—Delete personal information or data from your mobile device prior to disposing of it or turning it in for recycling. For step-by-step instructions on how to delete all personal information from your device, see the section entitled “master clear” or “delete data” in the user's guide.

If you have further questions regarding how the use of your mobile device may impact your privacy or data security, please contact Motorola at privacy@motorola.com, or contact your service provider.

Smart Practices While Driving

Drive Safe, Call Smart

Check the laws and regulations on the use of mobile devices and their accessories in the areas where you drive. Always obey them. The use of these devices may be prohibited or restricted in certain areas—for example, handsfree use only. Go to www.motorola.com/callsmart (in English only) for more information.

Your mobile device lets you communicate by voice and data—almost anywhere, anytime, wherever wireless service is available and safe conditions allow. When driving a car, driving is your first responsibility. If you choose to use your mobile device while driving, remember the following tips:

- **Get to know your Motorola mobile device and its features such as speed dial and redial.** If available, these features help you to place your call without taking your attention off the road.
 - **When available, use a handsfree device.** If possible, add an additional layer of convenience to your mobile device with one of the many Motorola Original handsfree accessories available today.
- **Position your mobile device within easy reach.** Be able to access your mobile device without removing your eyes from the road. If you receive an incoming call at an inconvenient time, if possible, let your voicemail answer it for you.
- **Let the person you are speaking with know you are driving; if necessary, suspend the call in heavy traffic or hazardous weather conditions.** Rain, sleet, snow, ice, and even heavy traffic can be hazardous.
- **Do not take notes or look up phone numbers while driving.** Jotting down a “to do” list or going through your address book takes attention away from your primary responsibility—driving safely.
- **Dial sensibly and assess the traffic; if possible, place calls when your car is not moving or before pulling into traffic.** If you must

make a call while moving, dial only a few numbers, check the road and your mirrors, then continue.

- **Do not engage in stressful or emotional conversations that may be distracting.** Make people you are talking with aware you are driving and suspend conversations that can divert your attention away from the road.
- **Use your mobile device to call for help.** Dial 999 or other local emergency number in the case of fire, traffic accident, or medical emergencies.*
- **Use your mobile device to help others in emergencies.** If you see an auto accident, crime in progress, or other serious emergency where lives are in danger, call 999 or other local emergency number, as you would want others to do for you.*
- **Call roadside assistance or a special non-emergency wireless assistance number when necessary.** If you see a broken-down vehicle posing no serious hazard, a broken traffic signal, a minor traffic accident where no one appears injured, or a vehicle you know to be stolen, call roadside assistance or other special non-emergency wireless number.*

* Wherever wireless phone service is available.

MOTOROLA and the Stylized M Logo are registered in the US Patent & Trademark Office. The Bluetooth trademarks are owned by their proprietor and used by Motorola, Inc. under license. Java and all other Java-based marks are trademarks or registered trademarks of Sun Microsystems, Inc. in the U.S. and other countries. Microsoft and Windows are registered trademarks of Microsoft Corporation; and Windows XP and Windows Media are trademarks of Microsoft Corporation.

© 2008 Motorola, Inc. All rights reserved.

Caution: Changes or modifications made in the radio phone, not expressly approved by Motorola, will void the user's authority to operate the equipment.

Note: The functions available on this handset may vary in different regions and nations. Please contact your local customer services centres, agencies or retailers if you have any question about the handset functions. Motorola reserves all rights to revise and change this manual without obligation to notify any person of such revisions or changes. The pictures and simulated screenshots are enhanced to show details for ease of reference. Please refer to your handset for actuality.

Manual Number: 68000201407

accessories



more information



GOTO

accessories: www.motorola.com.hk

user's guide: www.motorola.com.hk



68000201407